

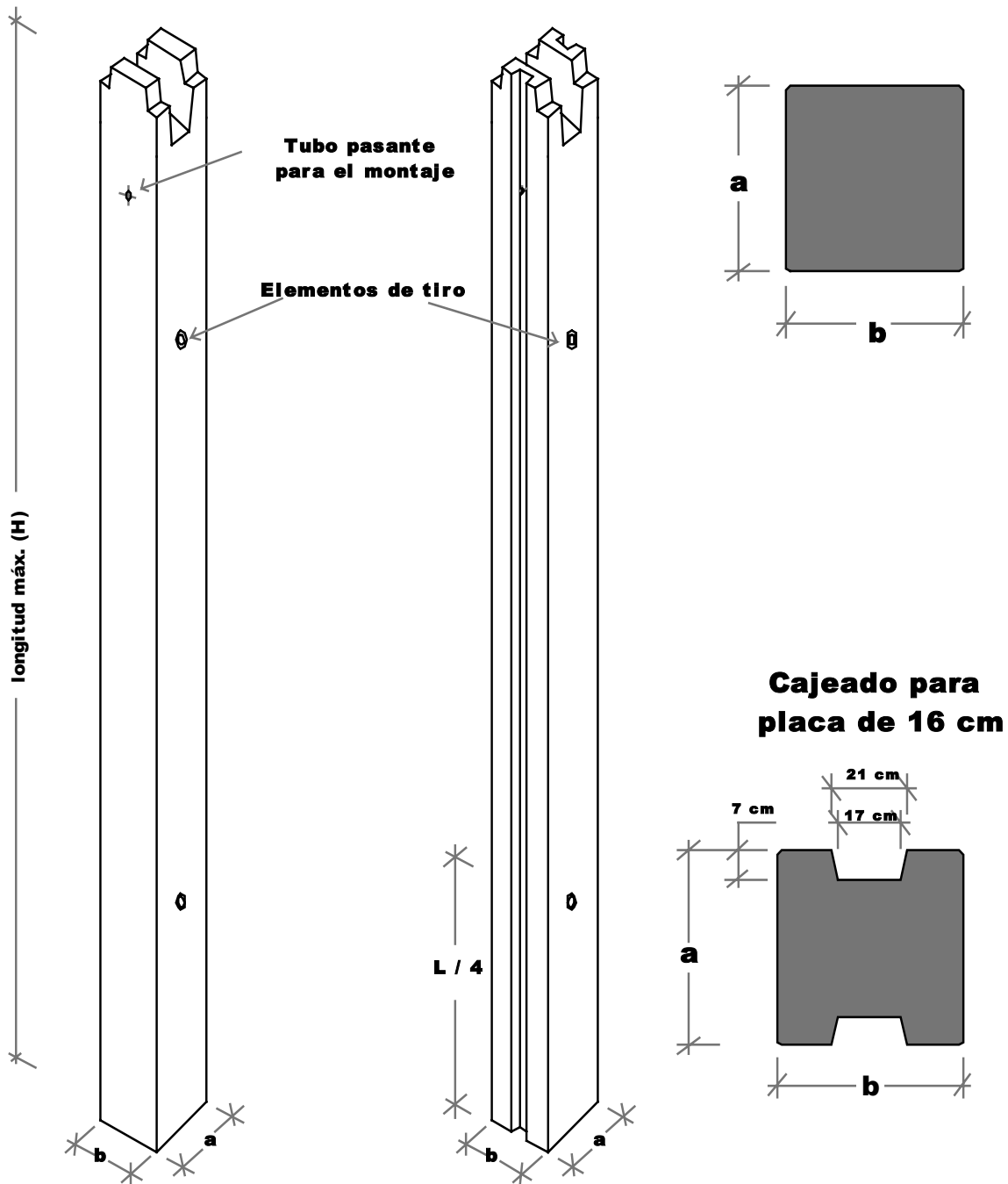

PILARES



FOTO



CARACTERÍSTICAS TÉCNICAS

Tipo a x b cm	Materiales		Peso Propio kN/m	H máxima m	Resistencia
	Acero	Hormigón			al Fuego
40 x 40	B-500SD	HA-35	4,00	10,00	R 240
40 x 50			5,00		
40 x 60			6,00		
50 x 50			6,25	15,00	



PILARES UNIONES CON CIMENTACION

Empotramiento en cáliz

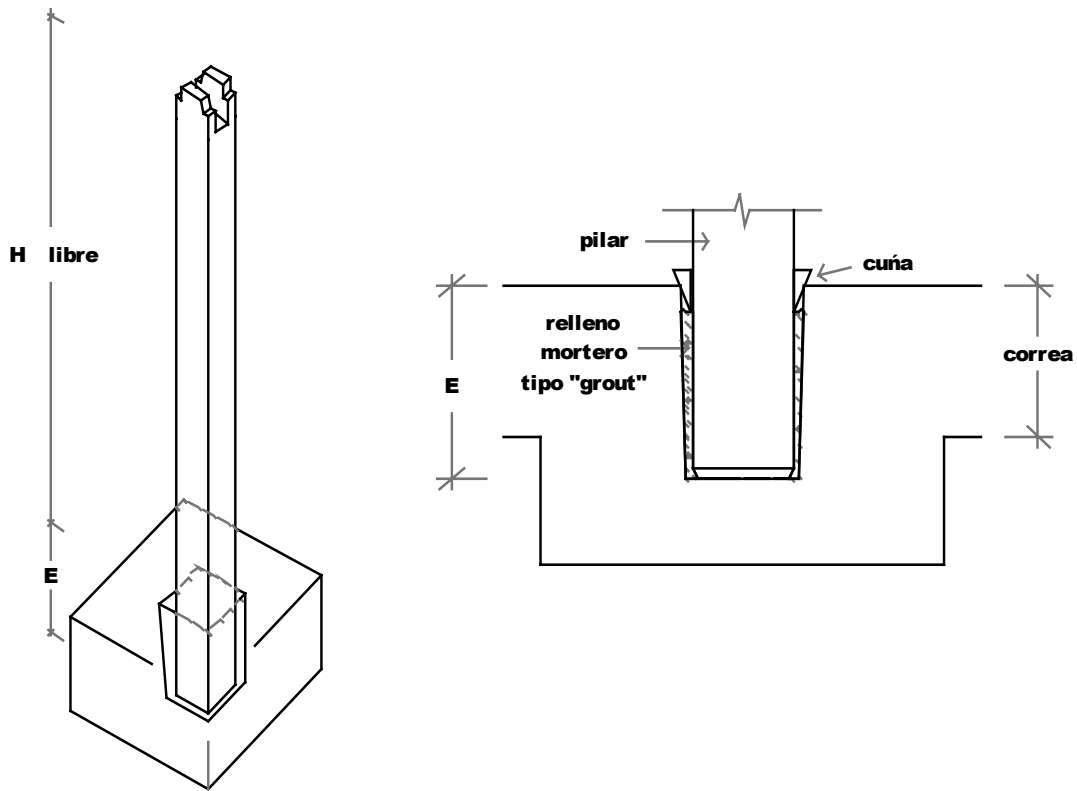

Con armadura en espera para vainas

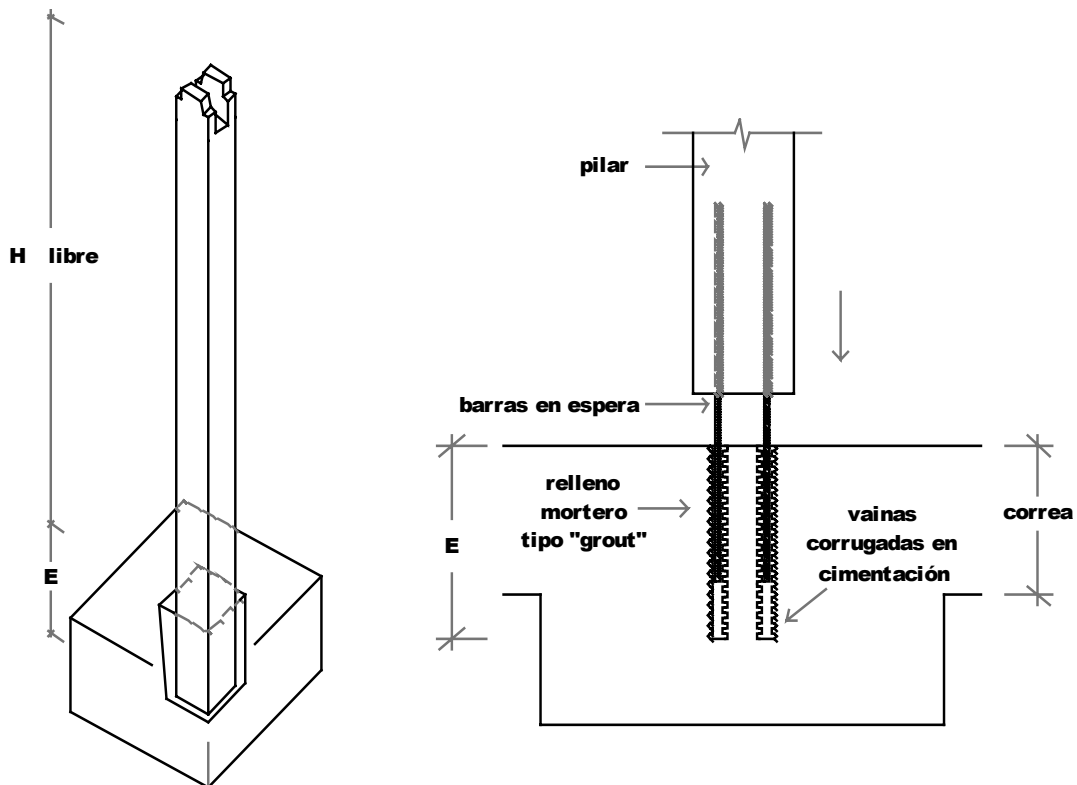



PILARES MÉNSULAS

Ménsula para puente grúa

vista

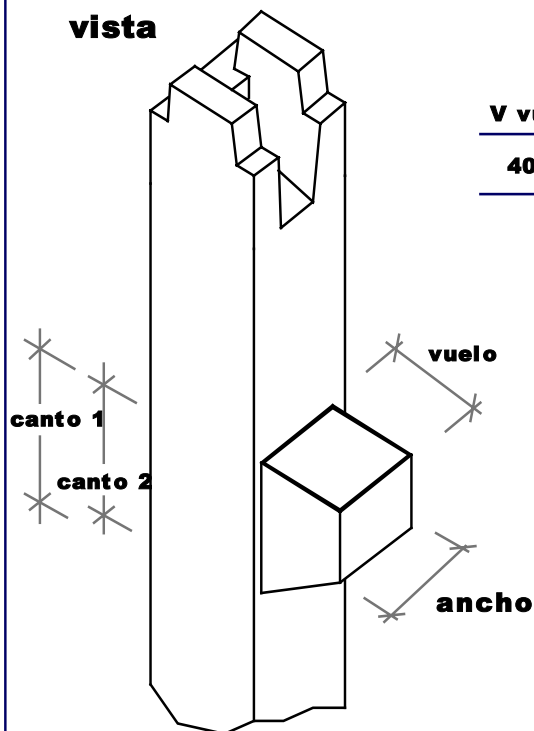

V vuelo	A ancho	C1 canto	C2 canto
40 cm	35 cm	60 cm	48 cm

planta

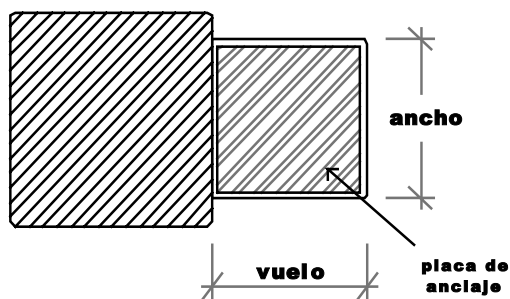

Ménsula para forjado

vista

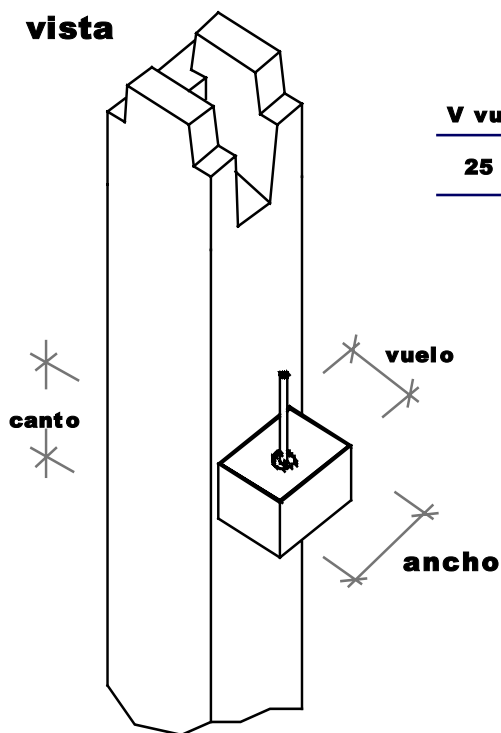

V vuelo	A ancho	C canto
25 cm	40 cm	25 cm

diámetro varilla
16 mm
20 mm
25 mm

planta

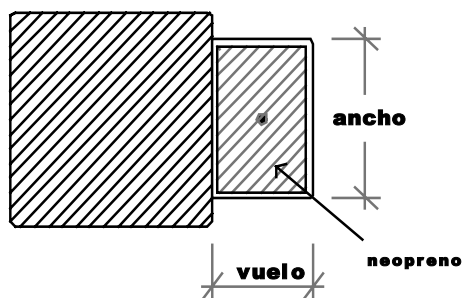



PILARES CABEZAS DE APOYO

Cabeza carga a dos caras

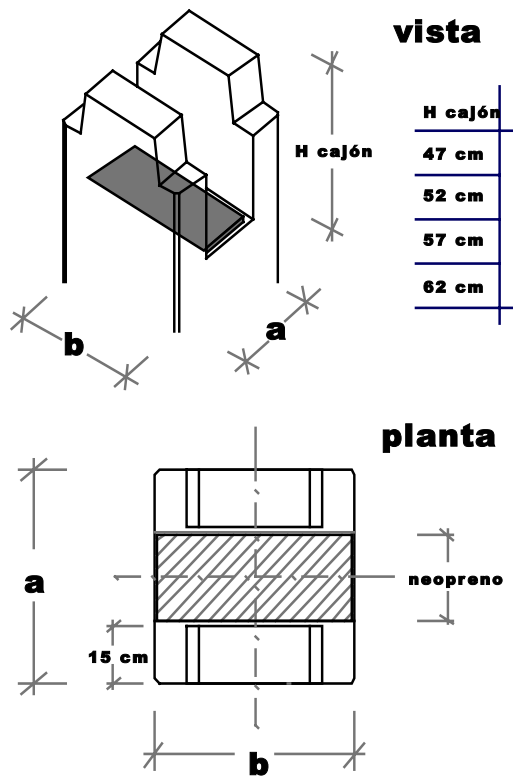

Cabeza carga a dos caras ranurado

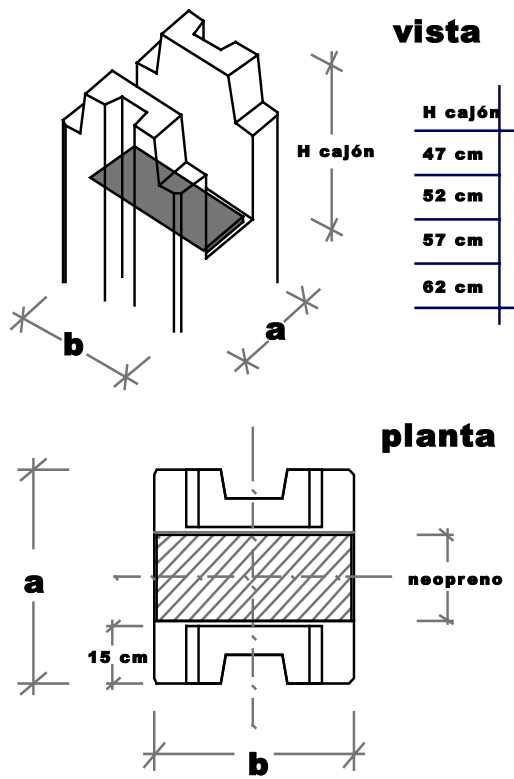

Cabeza para vigas piñón

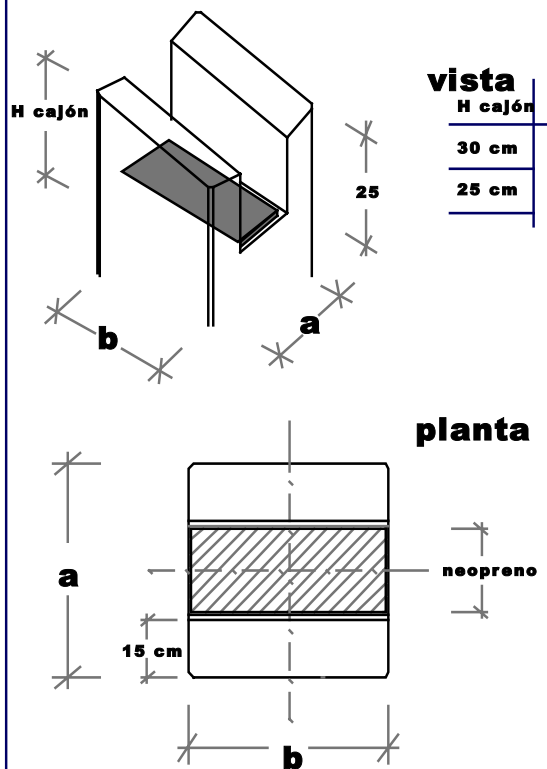

Cabeza con varillas para viga

