

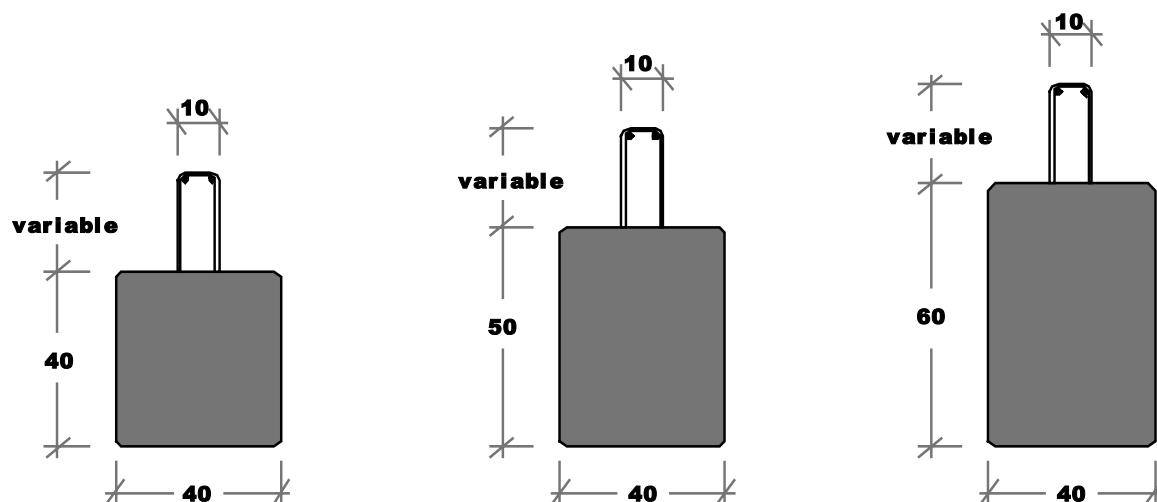

**VIGAS CARGADERO**

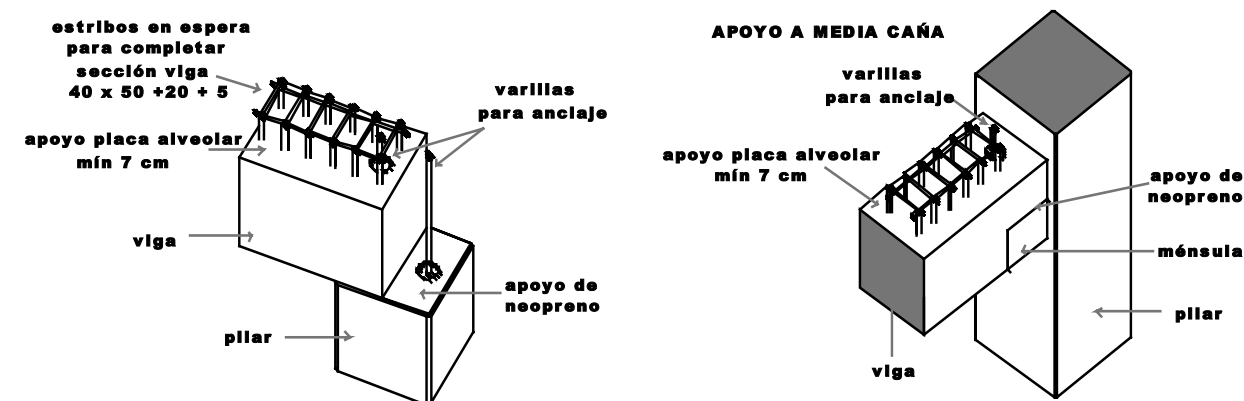

**DETALLES DE APOYOS DE VIGAS**



**DETALLES DE APOYOS DE LOSAS ALVEOLARES**

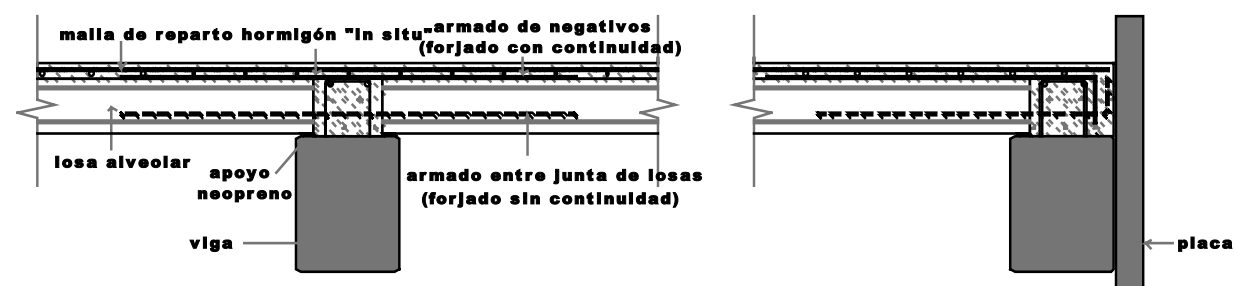

**FOTO**



**CARACTERÍSTICAS TÉCNICAS VC40**

TIPO	VC4040		VC4050		VC4060	
Variable (cm)	20	25	25	30	30	35
M máximo (mkN)	430,00	470,00	740,00	798,00	900,00	1000,00
Peso propio Pp (kN/m)	6,00	6,50	7,50	8,00	9,00	9,50
Resistencia al fuego (min)	R 90					